



Please dispose of packaging for the product in a responsible manner. It is suitable for recycling. Help to protect the environment, take the packaging to the local amenity tip and place into the appropriate recycling bin.



Never dispose of electrical equipment or batteries in with your domestic waste. If your supplier offers a disposal facility please use it or alternatively use a recognised re-cycling agent. This will allow the recycling of raw materials and help protect the environment.

# 3" Diesel Water Pump



04917

FOR HELP OR ADVICE ON THIS PRODUCT PLEASE CONTACT YOUR DISTRIBUTOR,  
OR SIP DIRECTLY ON:  
TEL: 01509500400  
EMAIL: [sales@sip-group.com](mailto:sales@sip-group.com) or [technical@sip-group.com](mailto:technical@sip-group.com)  
[www.sip-group.com](http://www.sip-group.com)

*Please read and fully understand the instructions in this manual before operation. Keep this manual safe for future reference.*

# DECLARATION OF CONFORMITY

## Declaration of Conformity

We

SIP (Industrial Products) Ltd  
Gelders Hall Road  
Shepshed  
Loughborough  
Leicestershire  
LE12 9NH  
England

As the manufacturer's authorised representative within the EC  
declare that the

3" Diesel Water Pump - SIP Part No. 04917

**Conforms to the requirements of the following directive(s), as indicated.**

2006/42/EC	Machinery Directive
2000/14/EC	Noise Directive for outdoor use
2011/65/EU & 2015/863/EU	RoHS Directive
2016/1628/EU	EU Type Approval

**And the relevant harmonised standard(s)**

Measured Sound Power Level	The Guaranteed Sound Power Level
101 dB(A)	101 dB(A)

Document Ref: EX 74161

Signed:  .....

Mr P. Ippaso - Managing Director - SIP (Industrial Products)  
Ltd Date: 10/06/2021.



**Declaration of Conformity**

We

SIP (Industrial Products) Ltd  
 Gelders Hall Road  
 Shepshed  
 Loughborough  
 Leicestershire  
 LE12 9NH  
 England

As the manufacturer within the UK, England, Scotland & Wales, declare that the

3” Diesel Water Pump - SIP Part No. 04917

**Conforms to the requirements of the following directive(s), as indicated.**

Supply of Machinery (Safety) Regulations 2008

The Restriction of the Use of Certain Hazardous Substances in Electrical and Electronic Equipment Regulations 2012  
 Noise Emission in the Environment by Equipment for use Outdoors Regulations 2001

**And the relevant harmonised standards;**

Measured Sound Power Level	The Guaranteed Sound Power Level
101 dB(A)	101 dB(A)



Signed: .....

Mr P. Ippaso - Director - SIP (Industrial Products) Ltd  
 Date: 10/06/2021



Page No.	Description
4.	Safety Instructions Used Throughout This Manual
4.	Safety Instructions
7.	Specified Conditions Of Use
7.	Guarantee
8.	Technical Specifications
9.	Getting To Know Your Water Pump
11.	Assembly Instructions
12.	Operating Instructions
17.	Maintenance Instructions
19.	Troubleshooting
20.	Spare Parts Information
21	Notes Pages
22 & 23	UK & EU - Declaration Of Conformity

## SAFETY SYMBOLS USED THROUGHOUT THIS MANUAL



**Danger / Caution:** Indicates risk of personal injury and/or the possibility of damage.



**Hot Surfaces:** Indicates risk of possible burning due to hot surfaces created during normal operation.



**Note:** Supplementary information.



**Poisonous Fumes:** Indicates a risk of possible inhalation of harmful fumes if care is not taken.



**Flammable:** Indicates possible risk of combustion if care is not taken.

## SAFETY INSTRUCTIONS



**IMPORTANT:** Please read the following instructions carefully, *failure to do so could lead to serious personal injury and / or damage to the water pump.*

When using your water pump, basic safety precautions should always be followed to reduce the risk of personal injury and / or damage to the water pump.

Read all of these instructions before operating the water pump and save this user manual for future reference.

The water pump should not be modified or used for any application other than that for which it was designed.

This water pump was designed to drain cisterns, rainwater reservoirs, wells, ponds, swimming pools, storm drains, flooded cellars, boats and yachts etc.

If you are unsure of its relative applications do not hesitate to contact us and we will be more than happy to advise you.

Before each use of the water pump always check no parts are broken, the oil is at the correct level and that no parts are missing.

Always operate the water pump safely and correctly.

## NOTES

For spare parts visit: [www.sip-group.com/techzone](http://www.sip-group.com/techzone)

- Before starting or servicing this water pump, read and understand all instructions. Failure to follow safety precautions or instructions can cause equipment damage and/or serious personal injury. Retain all manuals for future reference.
- Never use this water pump for any application other than that specified by the manufacturer. Never operate this water pump under conditions not approved by the manufacturer.
- Never attempt to modify this water pump to perform in any manner not intended by the manufacturer.
- Use only products and parts recommended by the manufacturer for maintenance and repairs.
- Be sure that the water pump is operated only by persons who have read and who understand these instructions.
- Ensure that the water pump is placed on a flat level surface prior to and during operation. The water pump must not slide or shift during operation.
- Keep all untrained persons away from the water pump during operation.
- Do not allow persons wearing loose clothing or jewellery to start or operate the water pump. Loose clothing or jewellery may become entangled in moving components, causing equipment damage and/or personal injury.
- Be aware of moving parts and hot surfaces that occur during normal operation of this water pump.
- Never operate the water pump with damaged, broken or missing parts, or with any guards or covers removed.
- Do not refill the fuel tank while the engine is running.
- Be careful to prevent fuel spillage during refills.
- Be sure the fuel tank cap is securely in place before starting the engine.
- Allow the engine to cool before refuelling etc.
- Never refuel whilst smoking or in the vicinity of a naked flame, or any ignition source.
- Take care not to spill any fuel on the engine, exhaust or any part of the water pump.
- Should any fuel make contact with your clothes; change and wash them immediately.
- If any fuel makes contact with your skin wash with soap and water immediately.
- If you swallow any fuel, inhale any vapour or allow contact with your eyes, seek medical advice immediately.
- Be sure to store diesel in clean containers that do not contain water, dirt or rust because this will reduce the life of the engine; ensure that all local fuel storage laws are followed.
- Never operate this water pump in an explosive atmosphere or near any flammable sources.
- Always operate this water pump in a well ventilated area to reduce the risk of suffocation.

## SAFETY INSTRUCTIONS...cont

- Turn off the engine before performing any service or maintenance to the unit.
- Never drag the water pump with hoses etc. to move it; only move the water pump with the carrying handles.
- Never cover the water pump or restrict the exhaust or air flow in any way.
- Always ensure that the water pump is at least 1 m (3ft) away from any walls or buildings to allow correct air flow.
- Avoid inserting hands or other objects into the inlet or the outlet of the pump.
- Always check the pump regularly, and take it out of service if the water is likely to freeze.
- When not in use, always ensure that the pump is fully drained of any water and store it in a warm environment to protect it from frost damage.
- Understand the operating environment; Before each use the operator should assess, understand and where possible reduce the specific risks and dangers associated with the operating environment. Bystanders should also be made aware of any risks associated with the operating environment.



**Caution:** anyone who operates this water pump should read and fully understand all of the instructions and warnings in this manual.



**Hot Surfaces:** During normal operation certain parts of this water pump will become hot. **ALWAYS** stay alert and be aware of hot components / surfaces. Allow the engine to cool before attempting to move, clean or maintain the water pump.



**Poisonous Fumes:** Exhaust fumes produced during normal operation are poisonous. **Do not** operate this water pump in enclosed areas; always ensure adequate ventilation.



**Flammable:** The fuel used to run this water pump (diesel) is highly flammable. Never re-fuel the water pump whilst it is still running. Store unused fuel safely and away from children and in accordance with local regulations / laws.



**CAUTION:** The warnings and cautions mentioned in this user manual can not cover all possible conditions and situations that may occur. It must be understood by the operator that common sense and caution are factors which cannot be built into this product, but must be applied.

## TROUBLESHOOTING



**Note:** Some of the following operation should only be carried out by a suitably qualified person. If in doubt contact SIP or your distributor for guidance.

Symptoms	Possible Causes	Possible Solutions
<i>No Output From Pump.</i>	<ul style="list-style-type: none"> <li>• Pump not fully primed.</li> <li>• Inlet pipe leaking.</li> <li>• Filter / Strainer clogged.</li> <li>• Suction / overall head too high.</li> <li>• Damaged pump seal.</li> </ul>	<ul style="list-style-type: none"> <li>• Prime the pump (see page 14).</li> <li>• Tighten clamps / replace damaged pipe.</li> <li>• Clean filter / strainer.</li> <li>• Reduce the height to recommended levels.</li> <li>• Replace pump seal.</li> </ul>
<i>Low Water Flow.</i>	<ul style="list-style-type: none"> <li>• Filter / strainer, pipeline obstructed.</li> <li>• Inlet pipe leaking.</li> <li>• Worn / damaged impellor.</li> <li>• Suction / overall head too high.</li> </ul>	<ul style="list-style-type: none"> <li>• Inspect and clear obstruction.</li> <li>• Tighten clamps / replace damaged pipe.</li> <li>• Check and replace impellor.</li> <li>• Reduce the height to recommended levels.</li> </ul>
<i>Flow Stops Suddenly.</i>	<ul style="list-style-type: none"> <li>• Inlet connector loose and leaking.</li> <li>• Cavitation caused by too high a suction head.</li> <li>• Filter / strainer, pipeline obstructed.</li> <li>• Impellor obstructed.</li> </ul>	<ul style="list-style-type: none"> <li>• Check and tighten connector.</li> <li>• Reduce the height to recommended levels.</li> <li>• Inspect and clear obstruction.</li> <li>• Check and clear obstruction.</li> </ul>
<i>Pump Excessively Noisy &amp; Vibrating.</i>	<ul style="list-style-type: none"> <li>• Cavitation caused by too high a suction head.</li> <li>• Filter / strainer, pipeline obstructed.</li> <li>• Loose rotary component.</li> <li>• Unstable pump installation.</li> <li>• Air in the system.</li> <li>• Damaged or binding component.</li> </ul>	<ul style="list-style-type: none"> <li>• Reduce the height to recommended levels.</li> <li>• Inspect and clear obstruction.</li> <li>• Inspect and tighten loose part.</li> <li>• Stop operation and reposition pump.</li> <li>• Release air and prime the pump.</li> <li>• Inspect and repair / replace component.</li> </ul>



**Note:** For more detailed troubleshooting, see chapter 4 of the diesel engine manual supplied with the pump.

## MAINTENANCE INSTRUCTIONS...cont

3. Remove the air filter element.
4. If the air filter is damaged contact your local distributor to purchase a replacement, if the filter is dirty, remove and wash the sponge section of the filter in a solution of warm water and mild detergent and rinse thoroughly. Leave the filter to dry completely; For the main filter element, blow dry air through it from the inside out until the contaminants are removed from the filter.
5. Place the sponge section back over the main filter element then place both back into the original position and replace the air filter cover etc.



**Caution:** Take care when blowing air through the filter; ensure the correct protective clothing is worn such as a dust mask etc.

### CHECK THE FUEL TANK FILTER

#### Check The Fuel Tank Filter (periodically).

Just under the fuel cap is a fuel filter, check this filter periodically and remove any contaminants which may have accumulated.

1. Remove the fuel tank cap and filter.
2. Clean the filter and, if damaged replace.
3. Insert the filter back into place.
4. Ensure the tank cap is tightly secured.



**Note:** For more detailed maintenance instructions, see chapter 3 of the diesel engine manual supplied with the pump.

## SPECIFIED CONDITIONS OF USE

This water pump can be used to drain rain water, domestic waste water and to remove water from flooded rooms in emergency conditions. The pump can be used to transfer clean or moderately dirty water (no solids).

This pump is designed to be used in the following applications:

- Draining of cisterns, rainwater reservoirs, wells, ponds, swimming pools, storm drains, flooded cellars, boats and yachts.
- It is only for use with water and not chemicals or other substances that could damage the internal seals etc.
- The pump cannot be used for flammable, corrosive, explosive or dangerous liquids.

It should **never** be used where aquatic life is present such as in domestic, or commercial ponds, or similar.

## GUARANTEE

### Guarantee:

This SIP water pump is covered by a 12 month parts and labour warranty covering failure due to manufacturers defects. This does not cover failure due to misuse or operating the water pump outside the scope of this manual - any claims deemed to be outside the scope of the warranty may be subject to charges including, but not limited to parts, labour and carriage costs.

This guarantee does not cover consumables such as filters, oil & general maintenance items.

In the unlikely event of warranty claims, contact your distributor as soon as possible.



**Note:** Proof of purchase will be required before any warranty can be honoured.

## TECHNICAL SPECIFICATIONS

Model	3" Diesel Water Pump
Part Number	04917
Engine Type	OHV 4 Stroke, Air-Cooled, Single Cylinder
Engine Size	8.6HP (3600RPM)
Fuel Type	Diesel
Inlet Port	3"
Outlet Port	3"
Max Pumping Head	26mtrs
Continuous Pumping Head	24mtrs
Max Suction Head	6mtrs
Max Flow Rate	1000 Litres/Min (60m3/h)
Continuous Flow Rate	833 Litres/Min (50m3/h)
Fuel Tank Capacity	3.5Litres
Engine Oil	SAE 10W-30 (1.65 Litres Approx.)

## OPERATING INSTRUCTIONS...cont

### STOPPING THE WATER PUMP

*In an emergency:*

⇒ Turn the start/stop lever knob counter clockwise to the 'off' position.

*In normal conditions:*

⇒ Turn the start/stop lever knob counter clockwise to the 'off' position.

⇒ Turn the start key to the 'off' position.

⇒ Turn the fuel tap to off.

## MAINTENANCE INSTRUCTIONS



**Hot Surfaces:** Always ensure that the water pump is turned off and allowed to fully cool before any refuelling or maintenance procedures are carried out.



**Caution:** Always turn off the water pump and allow to fully cool before carrying out any maintenance procedures.

### CHANGING THE OIL

*Change The Engine Oil (After 20 hours - first use, then every 100 hours of use).*

1. Turn the oil filler cap counter clockwise and remove from the crankcase.
2. Loosen and remove the oil drain bung and allow the oil to drain into a suitable container.
3. Refit and tighten the oil drain bung once all of the oil has drained.
4. Fill the crankcase to the max level with fresh oil (see page 12); we recommend the use of SAE 10W-30 oil.
5. Replace the oil filler cap / dipstick.

### CLEAN OR REPLACE THE AIR FILTER

*Clean or Replace The Air Filter (every 50 hours of use).*

1. Remove the air filter cover wing nut.
2. Remove the air filter cover.



## OPERATING INSTRUCTIONS...cont



**Note:** It may take a few attempts to get the engine started, if it doesn't start first time follow 'Recoil Start' instructions a few more times.



**Note:** Once the engine has started slowly release the recoil and allow the cord to be retracted.

### ENGINE FAILS TO START

- ⇒ If the engine fails to start, loosen the nut on the pipe. Proceed to turn the key, or pull on the recoil starter until the air has been purged from the system.
- ⇒ When fully purged retighten the nut.

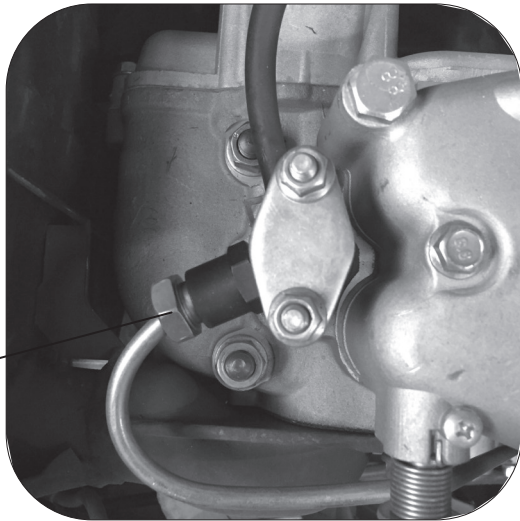

Nut



**Caution:** Take care when purging the air from the system; fuel will be released once all the air has been purged.



**Note:** This should only have to be done if the pump runs out of fuel and won't restart.

## GETTING TO KNOW YOUR WATER PUMP

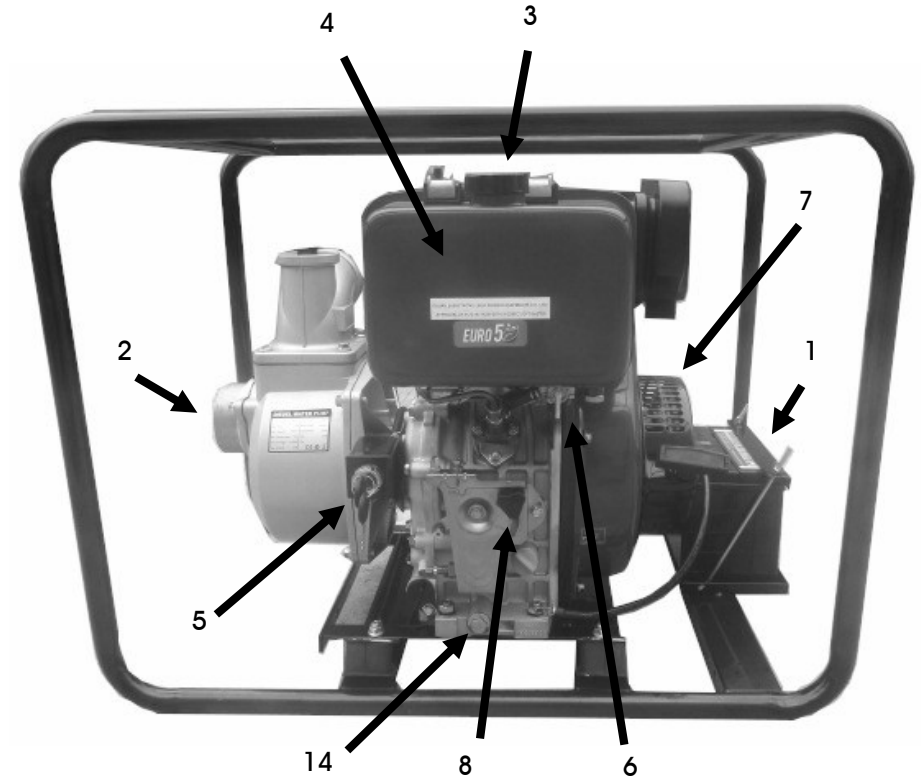

Ref. No.	Description	Ref. No.	Description
1.	Battery	5.	Ignition Switch
2.	Pump Inlet	6.	Fuel Tap
3.	Fuel Cap	7.	Recoil
4.	Fuel Tank	8.	Start / Stop Lever

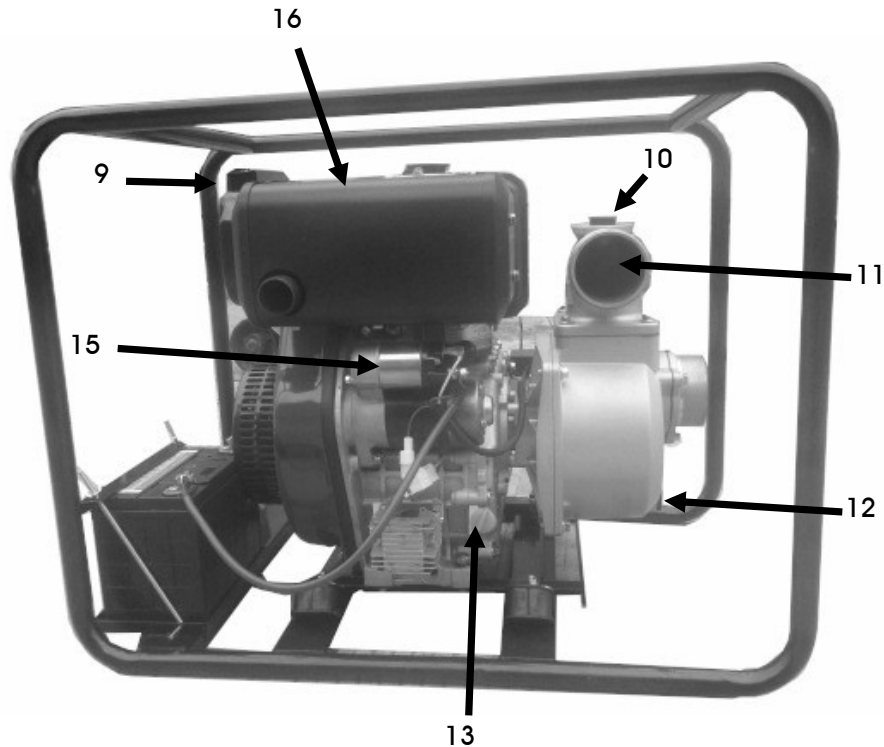

Ref. No.	Description	Ref. No.	Description
9.	Air Filter	13.	Oil Filler Cap / Dipstick
10.	Priming Port Bung	14.	Oil Drain Bung
11.	Pump Outlet	15.	Starter Motor
12.	Water Drain	16.	Exhaust

### STARTING THE ENGINE

#### Step 1:

⇒ Push the start/stop lever down and turn the knob clockwise to lock it.

Stop

Start

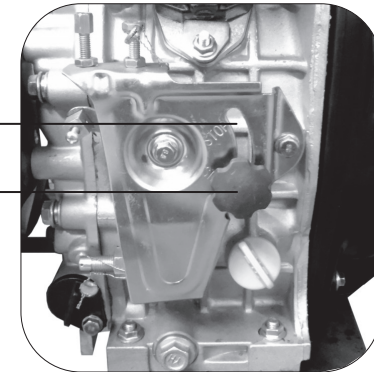

Fuel Tap

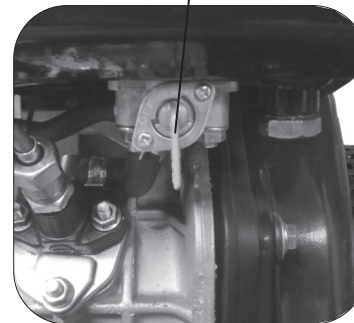

#### Step 2:

⇒ Turn the fuel tap to the 'on' position.

#### Step 3:

##### Electric Start:

⇒ Turn the key on to the start position, the starter motor will engage and the engine should start, once the engine has started release the key to the on position immediately.

##### Recoil Start:

⇒ Hold the water pump firmly with one hand, grip the recoil handle and slowly pull the recoil until it engages.

⇒ Return the recoil slowly back in.

⇒ Move the decompression lever to the down position.

⇒ Pull back sharply on the recoil handle, **DO NOT** let go of the handle instead, let it return slowly.

Decompression  
Lever

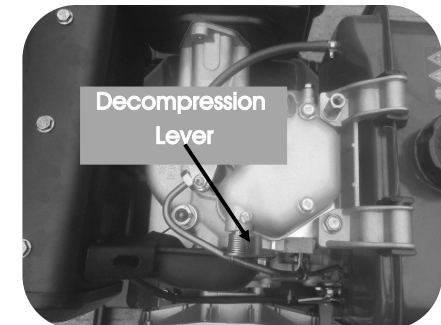

## OPERATING INSTRUCTIONS...cont

- Remove any spilled fuel from the water pump and surrounding area to avoid any risk of fire.

### PRIMING THE PUMP

Prior to use, the pump will need to be primed:

- ⇒ Remove the priming port bung.
- ⇒ Pour water through the port until it is full.
- ⇒ The amount of water needed will depend on different factors such as length of hose etc.
- ⇒ Once full, refit the priming port bung.

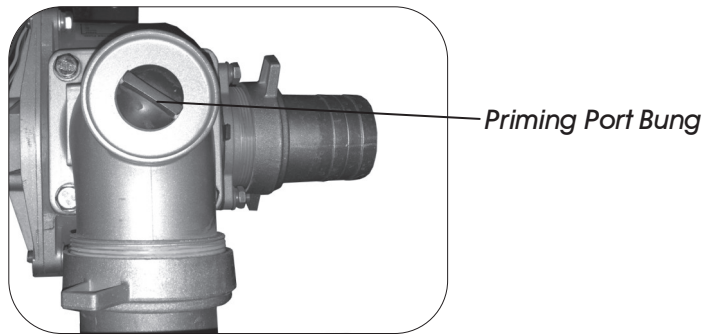

**Note:** The pump may need to be primed every time the pump is stopped (depending on different factors). The use of an NRV (non return valve) on the suction hose will reduce this issue.

Once primed the pump should be ready to run:

- ⇒ Start the engine (see page 15), if primed correctly the pump should start to pump water.

**Note:** The pump should not be run without water in the pumping chamber / impeller housing as this could cause damage.

## ASSEMBLY INSTRUCTIONS

### FITTING THE HOSE ADAPTORS

**Note:** The hose can be fitted directly to the pump if the hose has the correct female fitting, alternatively; follow the instructions below to fit the hose by means of a hose adaptor.

- ⇒ Fit the 3" inlet and outlet adaptors to the pump.
- ⇒ Slide the hose clips over the hose.
- ⇒ Fit the inlet and outlet hoses over the adaptors and secure with the hose clips.
- ⇒ Fit the filter / strainer at the opposite end of the suction hose.
- ⇒ Sit the end of the suction hose into the area / water to be cleared and the end of the outlet hose to where the water is to be pumped.

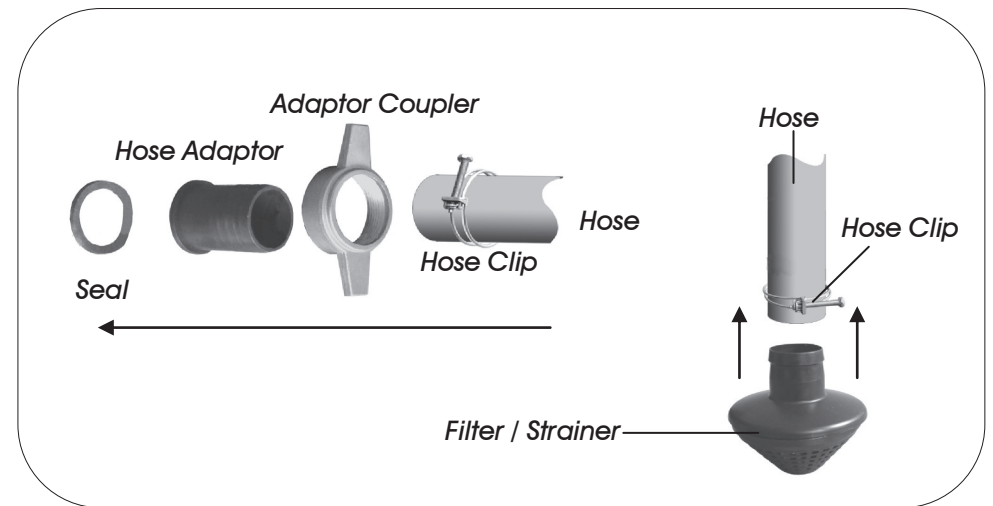

**Note:** Solid wall / super tough hose should be used instead of lay flat to ensure the pump will work to its capacity.

### FITTING THE BATTERY

- ⇒ Place the battery onto the battery plate, secure by using the strap provided.
- ⇒ Connect the wires to the negative and positive terminals using the nuts, washers and bolts provided. - (black) to the black wire and + (red) to the red wire, ensure that the terminals face inwards.

## OPERATING INSTRUCTIONS

### FILLING THE CRANKCASE WITH OIL / CHECKING THE OIL LEVEL



**Caution:** The water pump is drained of oil at the factory prior to shipping. SAE 10W-30 oil or equivalent is recommended for this water pump.



**Note:** When checking the oil level; always ensure that the water pump is placed on a firm level surface.

Ensure that the water pump is on a flat level surface.

- ⇒ Remove the oil filler cap / dipstick by turning it counter clockwise.
- ⇒ Slowly pour the oil into the crankcase.
- ⇒ Check the oil level by pushing the oil filler cap back into its hole up to the bottom of the threads (do not screw the cap in).
- ⇒ Once the oil level is between the upper and the lower marks on the oil filler cap / dipstick (see below), refit it and turn clockwise to fully tighten.

The oil level should be checked every 8 hours or daily.

The oil should be **changed** after the first 20 hours of operation; thereafter change the oil after 50 hours of operation or less if the water pump is operated under constant heavy loads or in high ambient temperatures.

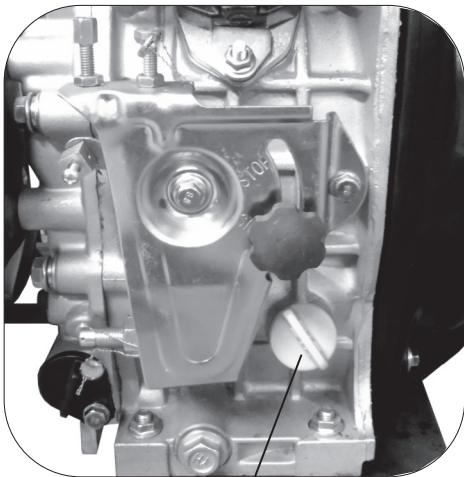

Oil Filler Cap / Dipstick



Upper Level

Lower Level

## OPERATING INSTRUCTIONS...cont



**Caution:** Ensure the oil level is maintained; Failure to do so will invalidate any warranty you may have.

### FILLING THE WATER PUMP WITH FUEL



**Flammable:** The fuel used to run this water pump (diesel) is highly flammable. Never re-fuel the water pump whilst it is running. Do not re-fuel near naked flames or other possible ignition sources.



**Note:** Never overfill the fuel tank; leave a small air gap at the top.  
**Fuel capacity: 3.3 Litres.**



**Note:** When re-fuelling always ensure that the fuel filter (supplied) is in place under the filler cap, as foreign matter or debris will cause damage to the engine and greatly reduce the life of the water pump.



**Note:** Diesel only

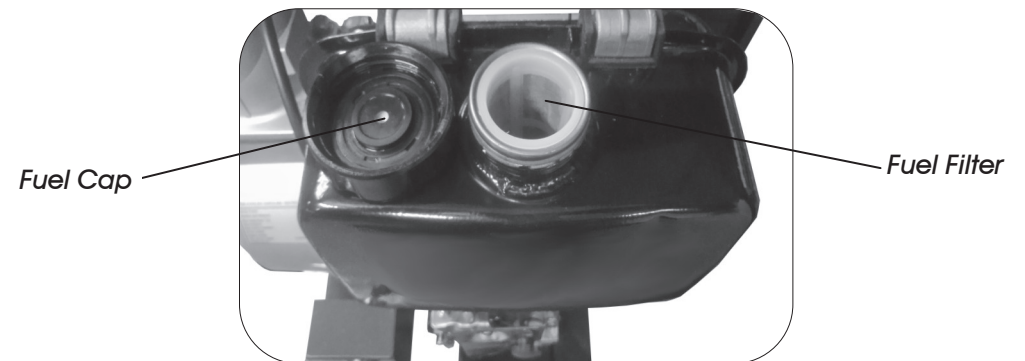

**To Fuel / re-fuel the water pump:**

1. Remove the fuel cap.
2. Carefully pour the diesel into the tank to the desired level (make sure the fuel filter is fitted), refit the fuel cap.